

RESEARCH & DEVELOPMENT OF AUDIO CAPACITORS

There has always been a great deal of debate within the audio industry about the effect of passive components on the perceived quality of reproduced sound. On one side of the debate it is argued that the effect of passive components in the signal path is negligible while at the other side there is much deliberation about the sonic qualities of various manufacturers' components accompanied by a thriving marketplace dealing in audio-grade components.

The purpose of this research was to find out if there were measurable differences between audio grade and standard capacitors and to identify what measurable parameters could be used to define the quality of an audio capacitor. The aim was to establish design rules and engineering processes for the manufacture of capacitors specifically for high quality audio use.

The capacitor types used in this investigation were metallised polypropylene for two reasons:

1. They are ClarityCap's main expertise and hence our product focus and
2. They are widely used throughout the audio industry

These capacitors are particularly used for crossover circuits where the component has to pass ac current while being subjected to significant potential difference across the plates. However, these capacitors are also used in amplifiers, microphones and general-purpose audio applications.

METALLISED FILM CAPACITORS

Metallised film capacitors are used in almost every area of electrical technology due to their relatively high stability with temperature and age. They have high reliability due, in part, to their ability to self-heal minor faults.

For a basic, parallel plate capacitor:

$$C = \frac{\epsilon_o \epsilon_r A}{d} \quad (1)$$

Where:	C	=	Capacitance (F)
	ϵ_o	=	Permittivity of free space = 8.85×10^{-12} (F/m)
	ϵ_r	=	Relative permittivity of dielectric
	A	=	Area of the plates (m^2)
	d	=	Distance between the plates (m)

Metallised film capacitors consisted of a polymer film substrate (typically polypropylene and polyester) with a sputter-deposited layer of metallisation (typically aluminum or zinc alloy), either wound on a spindle and then pressed flat or wound on a mandrel. The base film is shown in figure 1.

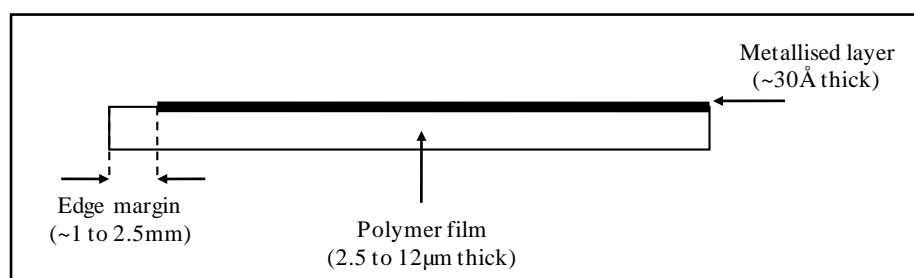

Figure 1: Metallised film as used in capacitors (not to scale)

Films are available in widths typically from 9 to 100 mm in discrete steps. A pair of films is wound together as shown in figure 2. The films are staggered so that the end spray will grip in order to form the terminals of the capacitor.

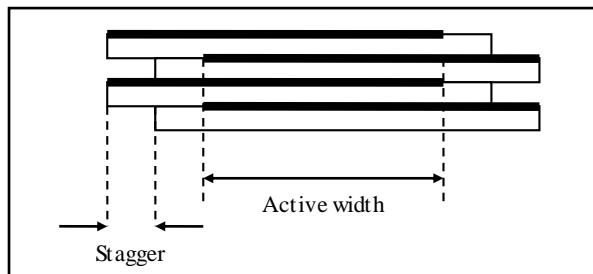

Figure 2: Layered films in metallised capacitor

When in this configuration, the effect of each plate is doubled because it faces plates both above and below itself. Hence, the capacitance is given by:

$$C = 2 \cdot \frac{\epsilon_o \epsilon_r A}{d} \quad (2)$$

MEASUREMENTS

We decided not just to focus on our own audio range of products, but also on commercially-available audio and industrial products. So, we examined over 350 metallised film capacitors - both audio grade and industrial – from our own ranges and from other manufacturers. In addition, brand new non-standard capacitor samples were designed and made in the factory with varying manufacture parameters such as film thickness and overall body aspect ratio.

A detailed programme of measurements was carried out to determine how Equivalent Series Resistance (ESR), capacitance and tan delta (loss factor) changed as a function of frequency. Measurements were taken up to 40kHz using a Wayne Kerr 6430B component analyzer. The measurement process was automated using NI LabView and each individual capacitor was subjected to a total of 819 electrical measurements.

The purpose of the measurements was to determine how these electrical quantities varied between components and also with component aspect ratio. The outcomes from the analyzer were also checked to see if there were any anomalous electrical effects that could not be accounted for using a standard electrical model.

The predicted form of the ESR as a function of frequency plot is shown figure 1. The blue line represents the dielectric loss; the red line represents the Ohmic loss and the black line is typical resultant ESR.

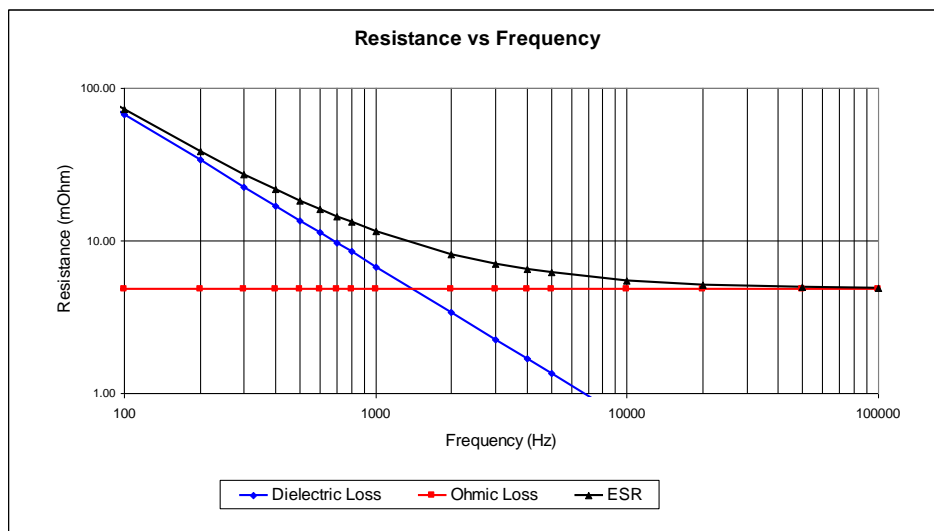

Figure 1. ESR as a function of frequency

The ESR value for all capacitors tested varied between 5 and 15 mΩ (at 1kHz) which, in the context of a typical loudspeaker crossover and wiring, is negligible. There were no observable electrical anomalies over the 40kHz measurement range.

Capacitance and tan delta also followed the predicted curves – for all capacitors. There were no electrical anomalies or deviations from the predicted values. Also, there was no significant variation with component aspect ratio, film thickness or cost.

At this point, there was little to indicate any measurable electrical difference between audio-grade capacitors and standard industrial products – let alone any difference between two different audio-grade capacitors!

MECHANICAL INVESTIGATIONS

After consulting with some large loudspeaker manufacturers, we began investigating mechanical vibrations of the capacitor in the laboratory. Initially, this was a simple observation exercise but, once actual resonance modes were observed, this became a full investigation.

Since film capacitors essentially constitute an elastic solid body, they are subject to vibration and mechanical resonance which may be excited by the application of voltage and the passage of current - particularly transients - through the capacitor.

Evidence for this mechanical resonance was presented to the Institute of Acoustics in a previous paper [3] and an example of typical results obtained using sine sweep and impulse excitation (rapid discharge) is shown in figure 2. The traces are obtained from the RMS amplitude of recorded acoustic emissions using a standard instrumentation microphone.

In all of the capacitors tested, resonances were observed in the upper audio frequency band between 10kHz and 30kHz with varying mean amplitude and Q factor according to the particular capacitor under test. In most cases the emissions were clearly audible.

In addition to the observed resonance in the upper audio band, a 'frequency doubled' peak could also be seen when driving the capacitor with a sweep signal, since the forces acting between a capacitor plates are always attractive regardless of the actual polarity.

Since reproduced sound can be considered as a combination of the weighted sum of a distribution of sinusoids, and impulses, these tests have a possible bearing on the quality of reproduced sound where capacitors are involved. The exciting mechanism has been shown to be mainly due to electrostatic forces which have the greatest magnitude in the outer turn of the capacitor winding and act inwards with a significant component at twice the driving frequency [6].

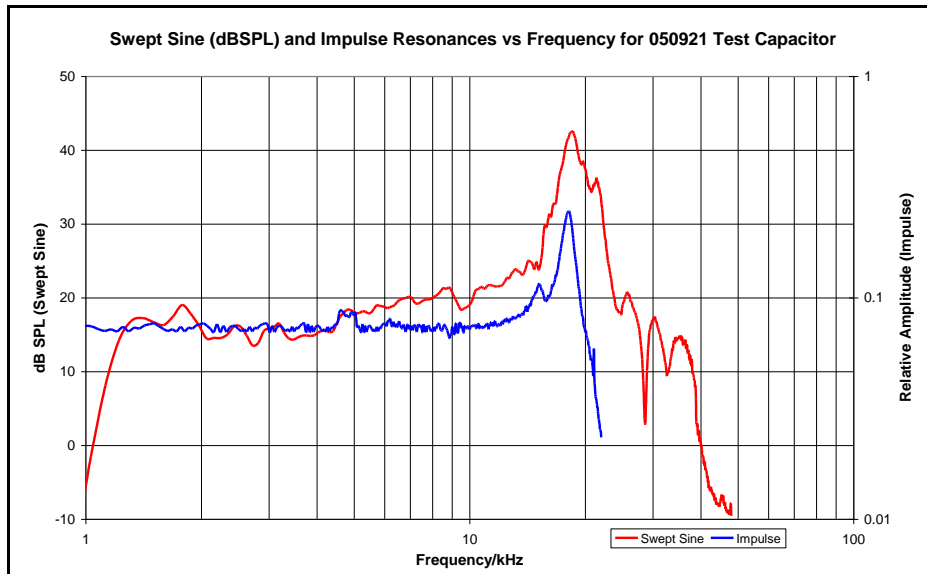

Figure 2. Typical results obtained using swept sine and impulse excitation.

The actual forces acting within a capacitor are quantifiable if electromagnetic theory is examined. The equation that quantifies the electrostatic (voltage) force acting upon the plates of a charged, planar capacitor is:

$$F_e = \frac{\epsilon \cdot A \cdot V^2}{2 \cdot d^2}$$

Where: F_e = Electrostatic force (Nm^{-1})
 V = Applied voltage (V)

The situation is changed when the planar capacitor plates are wound into a tight cylinder. The situation is shown in the diagram below.

Note that B is the winding "build-up" and is the number of turns (N) multiplied by twice the film thickness (d).

The same electrostatic force will appear across each alternate plate but apart from the first turn and the last turn, the forces on alternate plates will be oppositely directed and will cancel. Thus, only the first and last turns of dielectric will experience any compressive force.

Note that the diagram is drawn to scale and is a view of the capacitor end. At this scale (to show an adequate separation of the plates), the curvature of the winding core almost vanishes. At about a 1000:1 scale, the winding core would have a drawn diameter of 9 m.

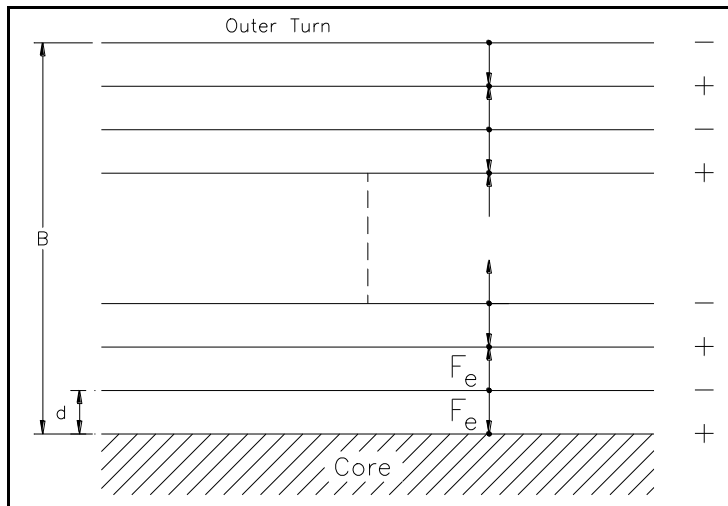

From equation 3, it can be seen that the strain in the inner and outer turns will be the same.

The actual compressive forces on the inner turn (F_i) and the outer turn (F_o) will be: -

$$F_i = \frac{\epsilon \cdot \pi \cdot D_s \cdot W_a \cdot V^2}{2 \cdot d^2} \quad (N) \dots\dots\dots 4$$

And
$$F_o = \frac{\epsilon \cdot \pi \cdot D_u \cdot W_a \cdot V^2}{2 \cdot d^2} \quad (N) \dots\dots\dots 5$$

Where D_s = core diameter (m)
 D_u = capacitor diameter (m)
 W_a = active width of capacitor (m)

The ratio of these two forces will be given by: -

$$\frac{F_o}{F_i} = \frac{D_u}{D_s} \dots\dots\dots 6$$

The forces on either side of a particular turn will not cancel exactly because the surface area of each successive turn will increase slightly as a result of increasing circumference.

Let A_n and A_{n-1} be the surface areas of the n^{th} turn and its adjacent partner respectively. The residual force on the n^{th} turn will be: -

$$\delta F_n = \frac{\epsilon \cdot (A_n - A_{n-1}) \cdot V^2}{2 \cdot d^2} = \frac{\epsilon \cdot \pi \cdot W_a \cdot (D_n - D_{n-1}) \cdot V^2}{2 \cdot d^2}$$

Where D_n = diameter of n^{th} turn etc. (m)

But $D_n - D_{n-1} = 2 \cdot d$

Therefore
$$\delta F_n = \frac{\epsilon \cdot \pi \cdot W_a \cdot V^2}{d} \quad (N)$$

and the total compressive force between inner and outer turns will be: -

$$F = \delta F_n \cdot N = \frac{\epsilon \cdot \pi \cdot W_a \cdot V^2 \cdot N}{d} \quad (N) \dots\dots\dots 7$$

Where $N = \text{total number of turns}$

It can be shown also that the 3 forces are related by: -

$$F = \frac{F_o - F_i}{2} \dots\dots\dots 8$$

Whenever the voltage applied to a capacitor changes, a current will flow through the capacitor. The instantaneous value of this current is given by: -

$$i = C \cdot \frac{dv}{dt} \quad A$$

This current will flow in the same direction in each electrode producing an attractive force between the electrodes. The current in each electrode will not be constant across the width of the capacitor but the sum of the currents in the two electrodes will be constant. This is illustrated in the schematic diagram below.

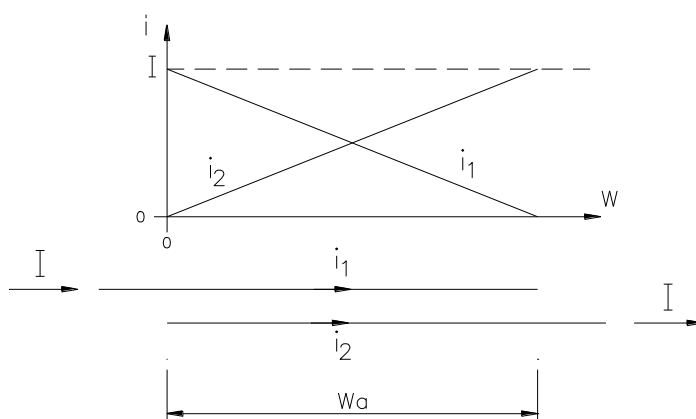

The situation can be modelled if we assume two current sheets flowing in the capacitor. The situation is represented graphically in the diagram below. The capacitor is assumed planar at this point.

$W_a = \text{active width of capacitor}$
 $l_w = \text{winding length of capacitor}$
 $K = K_1 = \text{sheet current density}$

$$K = \frac{i}{l_w} = \frac{C}{l_w} \cdot \frac{dv}{dt} \quad A \cdot m^{-1}$$

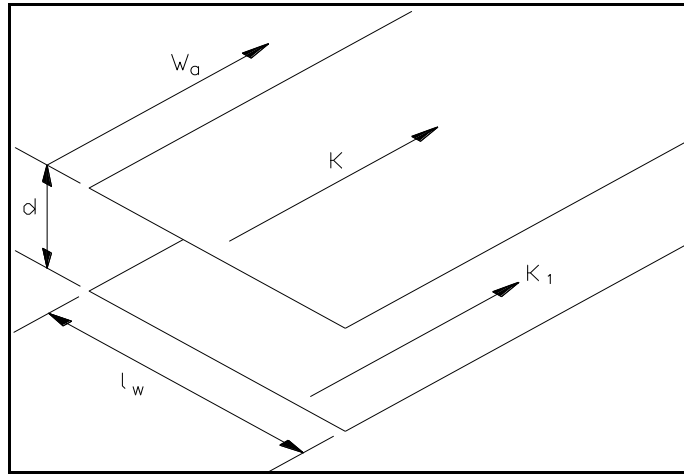

Note that no variation of current across the width is assumed here. If F_e is the electrodynamic force between the plates, it can be shown that: -

$$\frac{F_d}{W_a} = \frac{\mu_0 \cdot K \cdot K_1}{2 \cdot \pi} \left[2 \cdot l_w \cdot \tan^{-1} \left(\frac{l_w}{d} \right) - d \cdot \ln \left(\frac{d^2 + l_w^2}{d^2} \right) \right] \text{ N.m}^{-1} \dots\dots\dots 9$$

$$\mu_0 = 4 \cdot \pi \cdot 10^{-7} \text{ H.m}^{-1} \text{ (permeability of free space)}$$

LASER VIBROMETER MEASUREMENTS

The Salford laservibrometer is a Polytec PSV-400 scanning vibrometer, which is a velocity measurement system. A functional diagram of the system is shown below. Displacement information is derived from the recorded data using functions in the accompanying software.

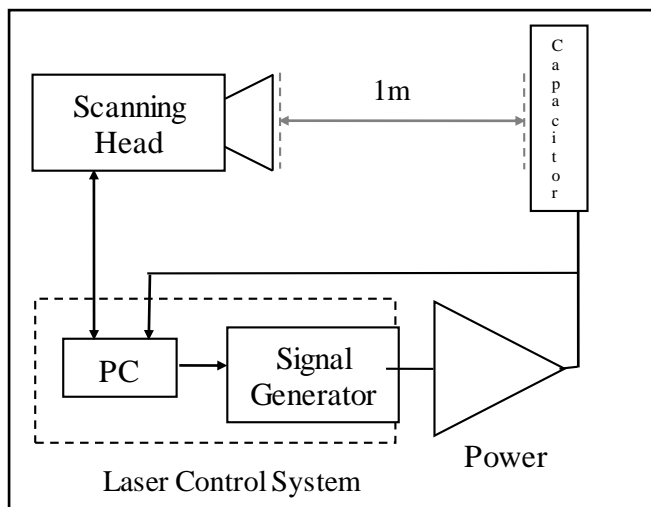

Functional diagram of laser vibrometer

The vibrometer system and its associated software have the capability to scan multiple points over a surface and to generate three dimensional graphs representing the movement of a surface. These graphs can be overlaid onto the images from the video camera in order to identify the parts of the object that are in motion.

At the resonant frequencies of each of the capacitors (as measured using the swept sine and impulse methods), the vibrometer measured maxima corresponding to the acoustic emission results.

Analyzing the data to produce surface plots of the displacement clearly showed the presence of a resonant mode of vibration which can be seen in figure 4 where the red areas represent regions of maximum surface displacement, and the light area in the middle of the capacitor body is a nodal point. Figure 5 shows a graphical representation of the resonance superimposed by the vibrometer software onto the video image.

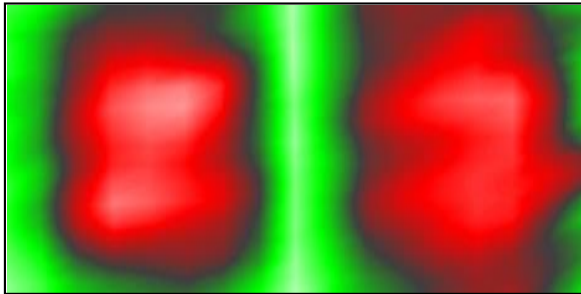

Figure 4. Surface displacement result from laser vibrometer

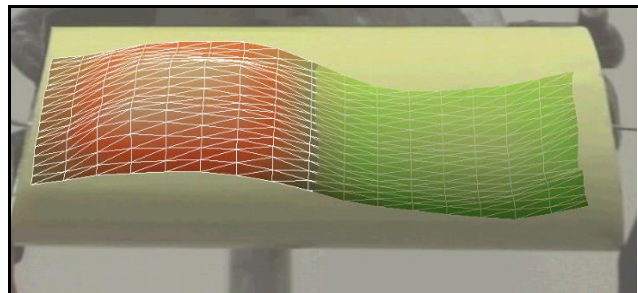

Figure 5: Resonance mode result from the laser vibrometer

LISTENING TESTS

In order to assess the quality of audio delivery for a given audio system, it is necessary to devise listening tests in which a panel of listeners is asked to make subjective judgments on key sonic attributes of selected programme material.

The actual audio differences using two different metallised film capacitors in the HF driver circuit of a first order crossover is very subtle and possibly only detectable by listeners who spend a lot of critical listening time evaluating and developing systems that they are very familiar with. As such, the listening tests posed significant challenges to both the investigators and listening panel.

The issues to be addressed were:

1. Does mechanical resonance degrade audio performance and,
2. How can any differences be assessed and quantified?

The notion that metal film capacitors from different manufacturers sound different is mainly anecdotal and based on the experience of designers working in the loudspeaker industry. No electrical or acoustic measurements have been made which suggests that one film capacitor performs differently to another. However, the mechanical resonance properties of capacitors do vary, and the focus of the tests described below has been to assess the audio effects of mechanical resonance and vibration in the crossover capacitors.

The tests involved two separate phases over about 4 months. The first stage was ABX type testing, which involved The Initial listening tests involved ABX methodology [5], the intention being to assess whether listeners could correctly identify condition X as A or B in a blind test between two film capacitors.

In order to 'train' the listeners, the test was carried out in two parts. In the first part, by way of a listener training exercise, the comparison was between capacitor A, a 4.7µF film capacitor and capacitor B a 4.7µF electrolytic capacitor since this comparison produced an identifiable audible difference, which would inform the following stage of testing where two film capacitors having low and high levels of mechanical resonance were compared and the differences were more subtle.

The initial ABX tests involved a panel of fourteen volunteer listeners comprising students and staff in the University. The listeners generally found the tests to be very difficult and quite tiring, and in general, the results from the initial ABX tests gave no usable outcome.

One surprising feature of the tests was that during the initial 'training' part of the tests where the electrolytic capacitor was compared with a film capacitor, and the difference was fairly audible, many of the listeners were unable to correctly identify A or B. In the second part of the tests, where the differences in audio delivery from the two film capacitors was much more subtle, the panel was unable to correctly identify A or B and no useful results were obtained.

When analyzing the results, it was found that some of the listeners had performed significantly better than others and this suggested that although the ABX method had not been successful overall, it may have an application in selecting listeners who seemed more able to detect the subtle differences in audio quality for subsequent tests.

The second stage was AB subjective testing. During these tests, listeners chose their own programme material could take as long as they needed and had the option of 'no preference'. The listeners had control over the switching between capacitor A and B, The main issue being to minimize stress to the listener during the tests. However, the tests were still blind as none of the listeners knew what capacitor A or B was.

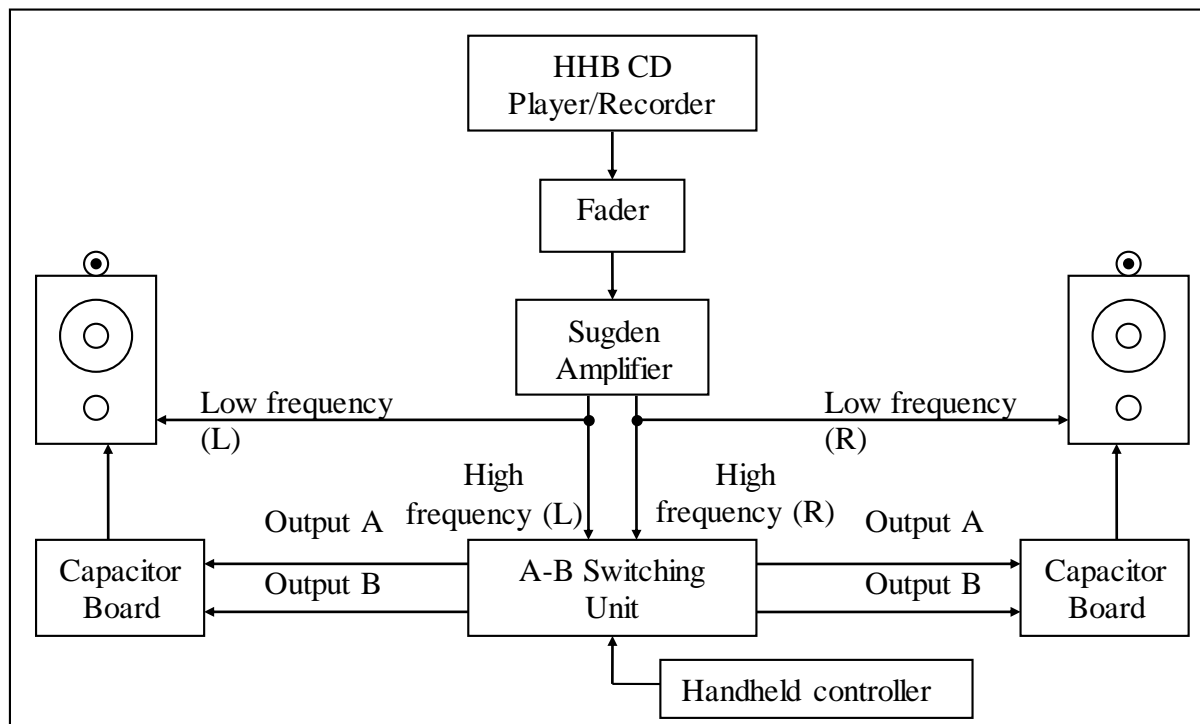

All of the listening tests were carried out using the equipment and experimental setup shown in figure 5. The source was an HHB CDR800 CD player/recorder playing material from standard CDs at 44.1kHz 16bit resolution. The audio output from the CDR800 was fed via a stereo fader directly to the input of the Sugden Music-master Class A DC-coupled power amplifier.

The outputs from the power amplifier were bi-wired to a pair of B&W 805 two way loudspeaker units with the cables for the LF driver going directly to the loudspeaker LF terminals, and the cables for the HF driver going to the switching box and then on to the capacitors and finally to the HF driver.

Using this method, the HF bound signal could be routed via capacitor A or capacitor B with the test subject operating the switching box.

Tests were carried out based on the ITU-R BS.1116-1 standard for the subjective assessment of small impairments in audio systems [7]. This methodology has been developed primarily for use in evaluation and comparison between audio codecs. However, since it is essentially about using a listening panel to assess the effect of small changes to an audio system, the investigators felt that it was appropriate as a basis for the design of further capacitor listening tests.



The ITU-R BS.1116-1[7] standard involves using a listening panel that is “trained” by familiarizing themselves with a set of programme material prior to the test sessions. In addition, the listening panel members were selected from the ‘Salford Hearing defender test panel’ on the basis of individual audiogram data, and also for listening experience and a general interest in high quality reproduced sound.

Critical listening experience, for the purposes of this investigation, was considered to be the process of subjectively evaluating the performance of high-quality audio systems for qualities such as spatial projection, distortion, clarity, and ambience. This could include experience of formal listening tests, project work or personal investigation, provided there had been a significant body of at least one type. Mixing and studio monitoring for audio production was also included if done frequently. Extensive training or experience in playing acoustic instruments was also a qualifying factor. An enjoyment or appreciation of music or involvement in live sound was insufficient to qualify as experience for this definition. The average test time was 22 minutes.

The number of panel members was 33. Listeners were asked to bring in material that they were familiar with and to spend as long as they needed to make judgments and record their preferences. Listeners were asked to state a preference using two capacitors where one showed a high degree of mechanical resonance and the other did not. The listeners were not affiliated with the project in any

way. At no point were the listeners allowed to see behind the speaker cabinets and none of the listeners knew what capacitor A or B was, either before or after the tests.

The listeners had significant degree of control over the process of the tests and were able to conduct the tests at their own pace, only making judgments when satisfied that they were certain about the outcome. The sonic attributes that listeners were asked to make judgments about were 'clarity' and spatial information. In addition, listeners were asked to indicate a preference, which was not to be prejudiced by any previous answer. Each question had an option to say "no difference" and results are shown in figures 6, 7 and 8.

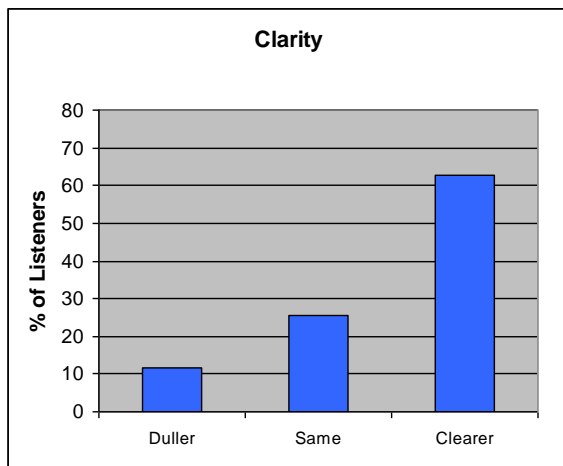

Results for 'clarity'

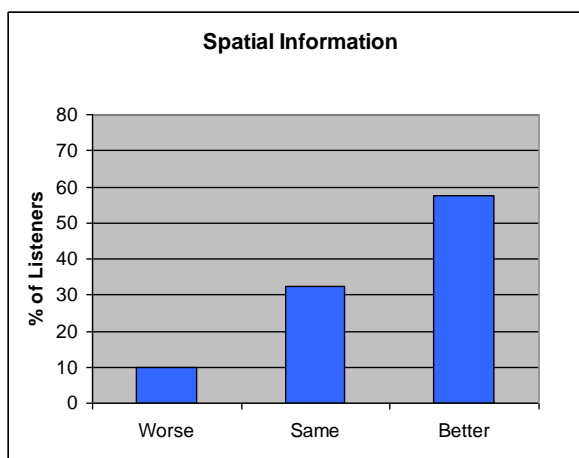

Results for 'spatial information'

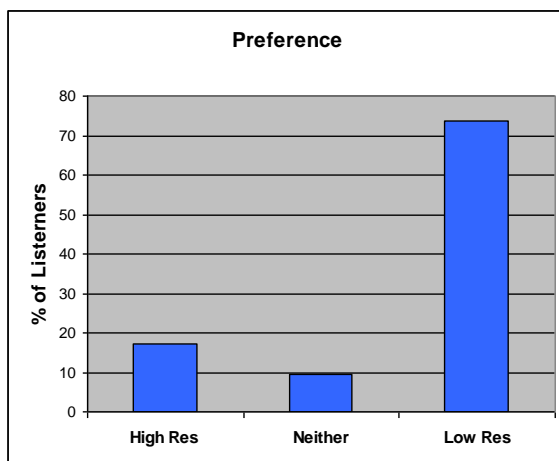

Results for Preferred Capacitor

NEW PRODUCTS

Taking this information and applying it to ClarityCap's manufacturing capabilities, 2 main processes were identified as important in controlling the resonances. For reasons of commercial confidentiality, these won't be directly identified here but will be referred to as processes 1 and 2.

Several months were spent refining the processes and working on various combinations to get the lowest mechanical resonance possible. The graph below shows the variation that was found processing one batch of capacitors in different ways.

The graph shows the results from a capacitor type that already had low resonance properties (**ClarityCap SA** series, 4.7 μ F) but was then processed to further reduce the resonance output. The y axis is calibrated to dB SPL and is derived from the frequency domain plots of the sound emitted by the capacitor.

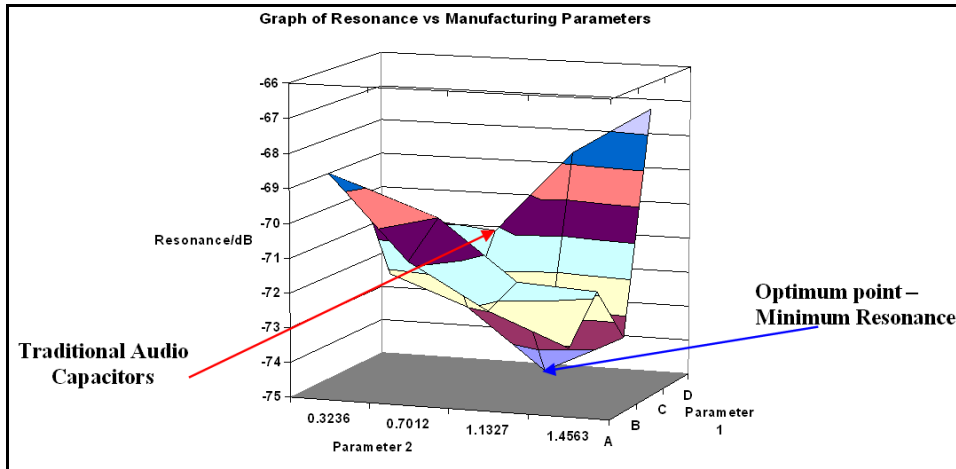

The capacitor represented by the optimum at the point of minimal resonance is the new **ClarityCap ESA** (Enhanced SA).

It should be noted that a reduction of 4.3dB SPL may sound small, but it represents a significant reduction in the resonance within the capacitor.

The investigation then turned to extra ways of reducing the magnitude of the resonances in a capacitor. It has long been known that differing metallization patterns are used in film capacitors to allow for different voltages and/or currents to be used or safety factors to be increased. However, we were unaware of any application of using different metallization patterns for reducing resonances for audio purposes.

Whilst there are several metallization patterns available to power capacitor designers, most of these involve breaking up the metallised pattern into segments to increase the breakdown strength of the capacitor. In return, they usually offer increased ESR as a result. We wanted a solution that would limit the resonances of the capacitors **without** compromising on our usual excellent ESR capabilities.



After examination using scanning electron microscope at the Materials Research Centre in Salford University, we began to understand the metallised layer more deeply.

We found – and now use – a pattern of metallising that breaks up the forces that cause the resonance across the surface of the capacitor whilst slightly **decreasing** the relative metallising component of the ESR of the capacitor. This film was then processed using the same parameters as mentioned above to produce a component where all steps had been taken to limit the natural resonances of the capacitor during manufacture.

A way of then damping any remaining traces of resonances was examined by encapsulating the components in a resin. The graph below represents the damping factor calculated from the time domain data of the impulse excited resonances:

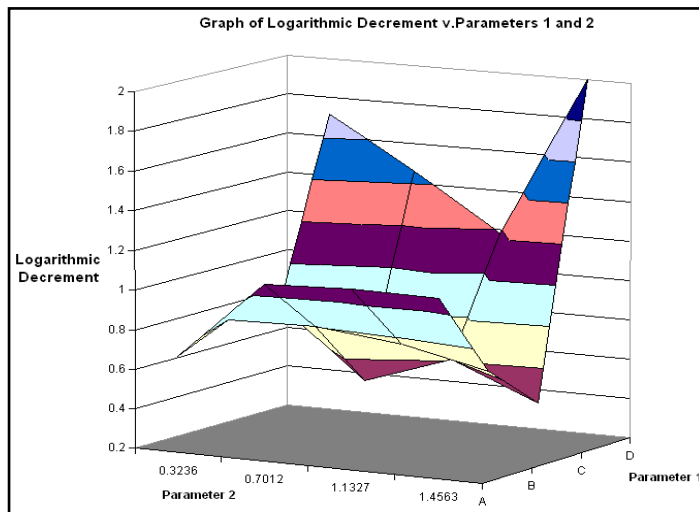

We took samples of various resin types to the Aeronautical Laboratories at Salford University and carried out hardness testing to obtain the most appropriate resin. We used Rockwell B and Vickers hardness tests.

We were looking for a resin that had the correct damping factor, i.e. the right amount of rigidity to restrict initial displacement of the capacitor walls whilst also having the right amount of damping to prevent ringing. The graph below shows 3 results:

1. a standard polyurethane resin used in capacitors which had excellent damping properties but was too soft to restrict initial displacements
2. a standard epoxy resin which had excellent restriction properties but was not good at damping, and
3. the resin used in the new MR series, which had a good combination of each.

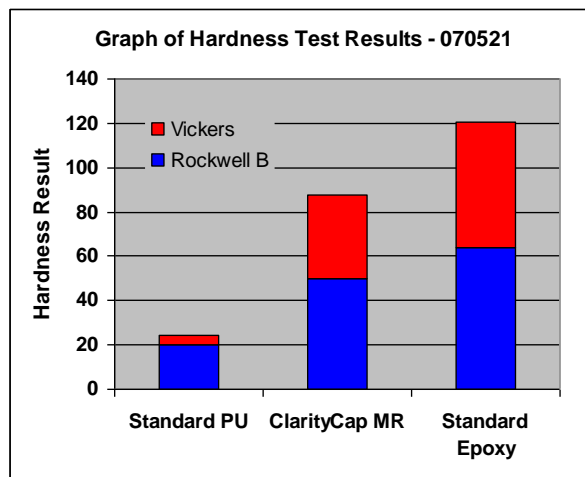

We now understand what makes the best resin for damping the resonances in the capacitor.

We then took all of the steps - different metallising, novel processing and the optimum resin encapsulation system - and used them to produce our most innovative audio component to date: the **ClarityCap MR** (Minimum Resonance) series.



This range is based on truly groundbreaking research into the detailed properties of audio capacitors and represents the product of the most detailed and up-to-date work ever carried out on the subject in our opinion.

REFERENCES

1. N. Williams, *Metallised Film Capacitors for High Frequency High Current Applications*, IEE Colloquium on Capacitors & Inductors for Power Electronics, 7th March 1996
2. W.J. Sarjeant, J. Zirnheld and F.W. MacDougall, *Capacitors*, IEEE Transactions on Plasma Science (Invited Review), Vol. 26, No. 5, October 1998
3. P.Dodds, N. Williams, P.Duncan, *Assessing the effects of loudspeaker crossover components on sound quality*, *Proceedings of the Institute of Acoustics Reproduced Sound 22*, November 2006
4. D.Daniels, *The futility of quantifying subjective audio measurements* 101st Convention of the Audio Engineering Society, November 1996, London
5. S. Bech and N. Zacharov, *Perceptual Audio Evaluation Theory, Method and Application*, Wiley 2006
6. P.Duncan, N. Williams, P.Dodds, *Forces in metal film capacitors*, *IEEE transactions on components and packaging*, Paper submitted for publication
7. ITU-R BS 1116-1: *Methods for the subjective assessment of small impairments in audio systems including multichannel sound systems*, 1997, International Telecommunications Union
8. S. Bech, "Selection and Training of Subjects for Listening Tests on Sound Reproducing Equipment", J. Audio Eng. Soc., vol.40, no. 7/8 (Jul./Aug. 1992)
9. P.Duncan, P.Dodds, N. Williams, *Audio Capacitors. Myth or Reality?*, 124th AES Convention, Amsterdam 2008.