

300BSEp power amplifier circuit diagram

300BSEp: power supply circuit diagram

300B single-ended stereo, power amplifier
 designed by Andy Grove, date: 01.05.04

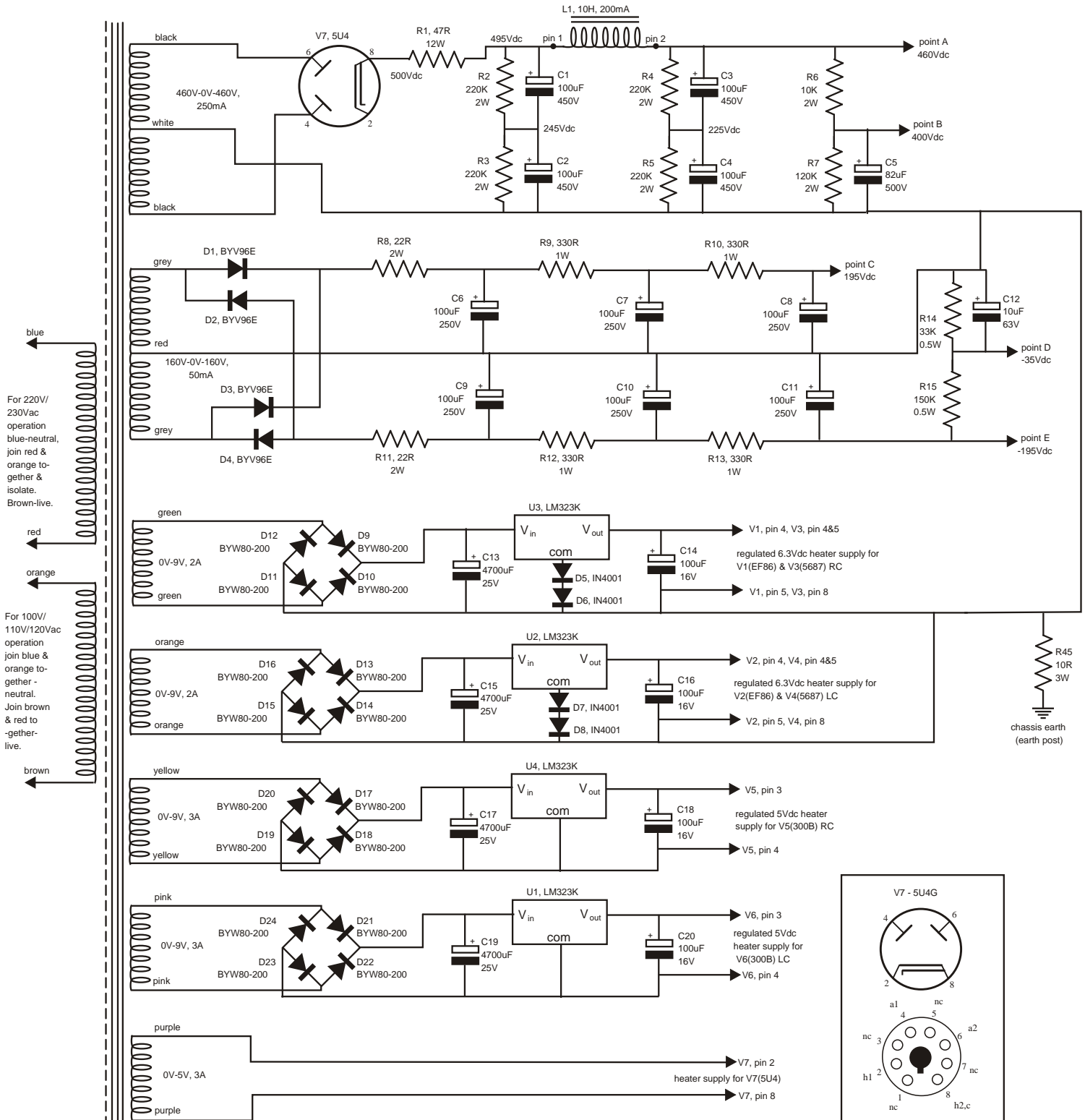

ALL TEST VOLTAGES WERE MEASURED WITHOUT THE SIGNAL INPUT GROUNDING.
 OUTPUTS CONNECTED TO A 60HM LOAD, RUNNING OFF A 240vac SUPPLY. PLEASE
 NB. TEST VOLTAGES CAN VARY WITHIN 20% OF STATED VOLTAGES, DUE TO VARIATIONS
 IN MAINS SUPPLY AND VALVE CHARACTERISTICS.

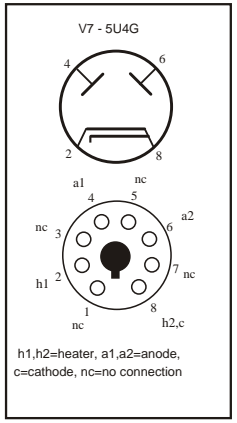

LC=left channel,
 RC=right channel

300BSEp: signal circuit diagram

300B single-ended stereo, power amplifier
 designed by Andy Grove, date: 01.05.04

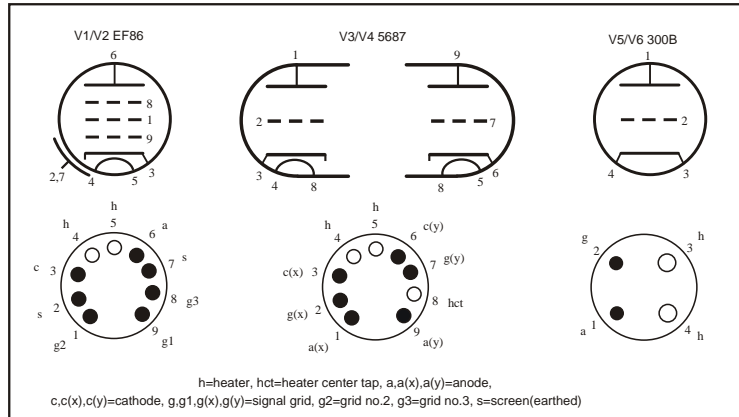
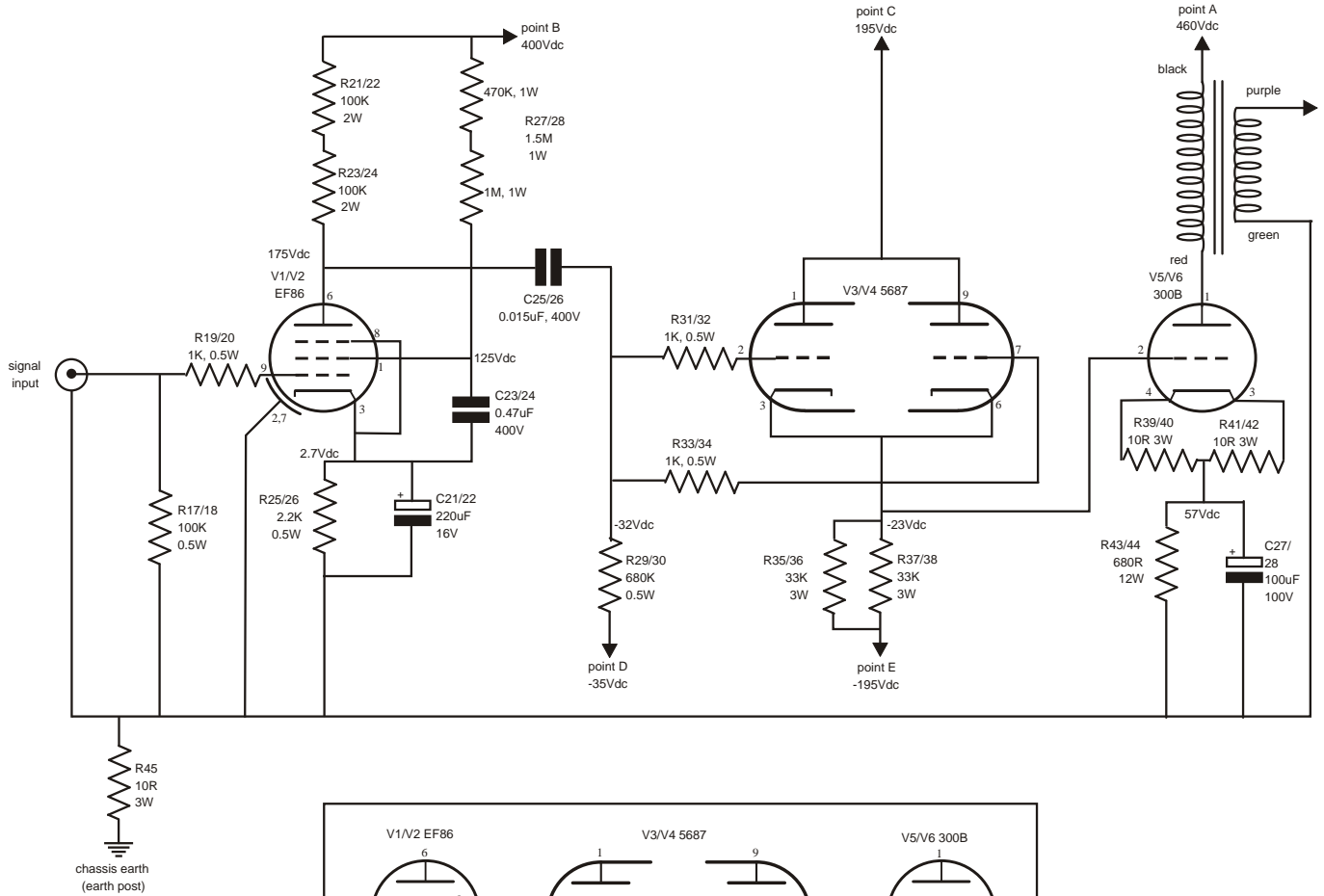

ALL TEST VOLTAGES WERE MEASURED WITHOUT THE SIGNAL INPUT GROUNDED.
 OUTPUTS CONNECTED TO A 60HM LOAD, RUNNING OFF A 240vac SUPPLY. PLEASE
 NB. TEST VOLTAGES CAN VARY WITHIN 20% OF STATED VOLTAGES, DUE TO VARIATIONS
 IN MAINS SUPPLY AND VALVE CHARACTERISTICS.